



WHALE GETS TO GRIPS WITH HAV REGULATIONS

Having recently launched its new anti-vibration gully boom control unit, Whale Tankers - the Solihull-based manufacturer of high quality vacuum tankers and jetting equipment - is already reporting unprecedented demand for the product, developed as a means of reducing health and safety concerns surrounding

hand-arm (HAV) vibration. Whilst now supplied as part of Whale's standard vehicle specification, many operators are upgrading existing equipment by installing the new gully boom control unit into their Whale fleets.

As Whale's Senior Engineering Manager, Andy Ellis states: "It's all about compliance, whilst also increasing operating efficiency. The new unit has been designed and developed to enable operators to meet Statutory Instrument 2005 No 1093 of The Control of Vibration at Work Regulations 2005, which has important health and safety implications, particularly in relation to hand-arm vibration (HAV) and High Impact Shocks (HIS).

"Forming part of Whale's ongoing philosophy of ensuring all of its equipment meets the latest legislative requirements, the gully boom unit was design engineered from the outset to enable customers to upgrade cost-effectively, thereby ensuring that equipment in operation prior to July of this year complies with the new regulations by July 2010," he added.

Take Whale Customer, London Borough of Wandsworth, who has already had the unit installed on two Whale gully emptying tankers. As Trevor Critchell, the Council's Transport & Fleet Manager states: "Not only do we want to take the lead when it comes to protecting the health and safety of our operatives, which the new unit enables us to do, ergonomically the gully boom control handle is far superior to its predecessor.

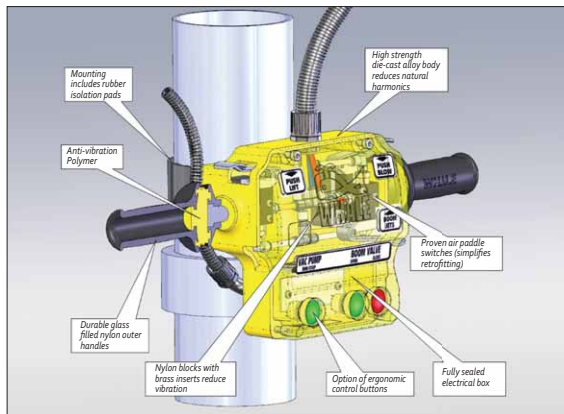

New **WHALE** anti-vibration gully boom control unit

If you add into the equation the ease with which existing gully booms can be upgraded, then it is understandable that operators are going to want to specify it."

In addition to benefiting from the specific features introduced into the design brief, the gully boom units specified by Wandsworth include optional electrical control buttons – vac pump engaged and boom valve (open and closed). These not only improve the unit ergonomically, they deliver improved functionality.



WHALE



TOPICS

"It's all about compliance, whilst also increasing operating efficiency."



REGULATIONS

S.I. 2005 No. 2093 The Control of Vibration at Work Regulations 2005 legislation came into force 6th July 2007 for new equipment, with a transitional period on equipment already in use before July 2007. The exposure limit value may be exceeded during the transitional period, until July 2010, as long as an organisation has complied with all the other requirements of the regulations and taken all reasonably practicable actions to reduce exposure as much as is possible.

The latest legislation measures the daily exposure in $m/s^2 A (8)$ and has two action levels:

Exposure Action Value (EAV) is a daily amount of vibration exposure above which employers are required to take action to control exposure. The greater the exposure level, the greater the risk and the more action employers will need to take to reduce it. For hand-arm vibration, the EAV is a daily exposure of $2.5 m/s^2 A (8)$.

Exposure Limit Value (ELV) is the maximum amount of vibration an employee may be exposed to on any single day. For hand-arm vibration, the ELV is a daily exposure of $5 m/s^2 A (8)$. This represents a high risk, above which employees should not be exposed.

Despite Whale's existing unit falling within the acceptable daily exposure limits as laid down by

the regulations, the company held the view that if exposure to vibration and high impact shocks could be reduced further then it should be.



As Whale's Andy Ellis states: "When we took detailed measurements of our original gully boom handles over a broad band frequency range that looked at both velocity and acceleration, and which gave an indication of the likely vibration emission in the field, it quickly became apparent that they already fell below the new action level (EAV). Despite this, we felt it was still necessary to design a new handle that would remove vibration and High Impact Shocks (HIS). At the same time we also wanted to focus on the field of ergonomics, by designing in the option for further control functions to be incorporated into the new gully boom handle."

DESIGN RATIONALE

In summation, the key motivators behind Whale instigating the development programme were as follows:

- 1) It should be recognised that agreed test methods do not always represent the way equipment is operationally used, so the actual level may be higher in some operational circumstances e.g. deeper gullies, number of gully's emptied, time spent emptying (trigger time), age of equipment, medium in the gully (product), competence and experience of operator and weather conditions.
- 2) Any assessment should also take into account that when operating a boom to clean a Gully pot, a banging action is necessary to break up the medium in the gully causing High Impact Shocks (HIS) to the hands, wrist and arm, and it is important to minimise these. Such conditions can also, over the long-term, result in a multitude of what are categorised as musculo-skeletal disorders (MSDs). And whilst there is no accepted definition, the HSE states that 'Musculo-skeletal disorders are the most common occupational illness in Great Britain, affecting some 1 million people a year.

Problems encountered are low back pain, joint and repetitive strain injuries of various sorts.'

- 3) The operational ease of gully cleaning can be greatly improved by the use of boom jets, but results in higher-level vibration.



- 4) Whilst various PPE should be used by operators, including gloves, they should not be relied upon to provide protection from vibration.
- 5) Gully emptying is not only undertaken outdoors, it is often carried out in cold and damp conditions that make any vibration potentially worse, particularly in relation to circulatory issues.

- 6) HSE advice for employers on estimating vibration exposure suggests it may be safer to double the figure given in the equipment handbook when estimating daily exposures.

In essence, employers have a legal responsibility to assess and minimise, and quite rightly so, the risks associated with work activities likely to cause MSDs. Legislatively, this takes in the Management of Health and Safety at Work Regulations 1999, s. A10 and the Manual Handling Operations Regulations 1992, s. A10.

What's more, another piece of legislation, 'The supply of Machinery (Safety) Regulations 2008 SI No. 1597' states: "Machine manufactures are obliged by the supply of Machinery (Safety) Regulations 2008 to design equipment that will reduce vibration risks

as low a level as possible, making use of the latest technology."

It is against such a backdrop that Whale Tankers clearly identified the need to develop its new gully boom handle. As Andy Ellis recalls: "We knew from our own experience, not to mention the feedback that we had received from our customers, that the effects of HIS and HAV needed careful consideration. The legislation that was already in place, including the latest regulations that have more recently been introduced, only served to confirm this. The next stage was to put the project into practice and we knew that the most important part of the exercise was the design brief itself. Because of this, we took the following factors into account."

DESIGN CRITERIA

1. A desire to isolate the hand from the main body. This would be achieved by designing a unique handle that featured the latest vibration dampening polymers and which would reduce HIS (High Impact Shocks) but be rugged enough to withstand harsh operating environments.
2. Design an anti-vibration mount to take the existing industry proven paddle switches.
3. Create the ability to isolate the main body from the gully down pipe.
4. Improve operational functionality in terms of ergonomics.
5. Deliver a design that could be easily retrofitted, thereby ensuring existing equipment was not made obsolete.
6. Make it possible to add extra control functions by developing ergonomic design principles, incorporating a weatherproof electrical housing.
7. Produce a rugged designed body unit using materials that, whilst strong enough to last in a hostile environment, remove vibration effectively.
8. Design a unit that was proportionately optimal for its use, whilst also being aesthetically pleasing.

The rest, as they say, is history. Whale's design and engineering teams set to work to create the new gully boom handle that successfully reduces the effects of vibration exposure. This has, in part, been achieved by manufacturing the main body of the unit from a robust and high strength die-cast alloy that takes out potentially harmful vibration frequency waves. What's more, the body has been protected using the process of chromate conversion before powder coating.

This is a highly effective process for alloys that provides outstanding protection against the effects of slow corrosion.



Serving to isolate the user from the main unit, Whale developed specially designed handles that are flexible but strong enough to withstand normal operating conditions. Moulded from three specific parts, the main body of the handle and the part connected to the die-cast alloy body deploys the use of glass filled nylon for strength and durability. Sandwiched in-between is an injected and specially formulated polymer unique to Whale that flows into the other parts to remove shocks and vibration associated with normal use, whilst also isolating the operator's hands from vibration.

Whilst Whale has retained the use of proven air operated paddle switches - for ease when retrofitting - these are now mounted on specially designed internal nylon blocks with brass inserts to help further reduce vibration during operation.



WHALE TOPICS

Whale has also paid attention to the way the anti-vibration gully boom control unit is fitted to the gully downpipe by using a bonded NBR (Natural Butane Rubber) anti-slip mounting as a means of delivering further isolation.

Additional vibration testing undertaken since the launch of the gully boom control unit has shown a greater reduction than anticipated. When comparing both new and old, the latest model is shown to isolate vibration and HIS (High Impact Shocks) by around of 65%. This constitutes a 50%

reduction from the body of the unit, and a further 15% emanating from body to handle.

Concluding, Andy Ellis said: "In designing and manufacturing the new handle, a great deal of investment has been made in specialist tooling, the latest processes and new material technology. Given the results that we now have access to in relation to the unit's ability to reduce the levels of vibration and High Impact Shocks, it is clear to see why customers are so keen to upgrade their existing equipment."

To further reduce vibration during operation, proven air operated paddle switches are mounted on specially designed nylon blocks with brass inserts.

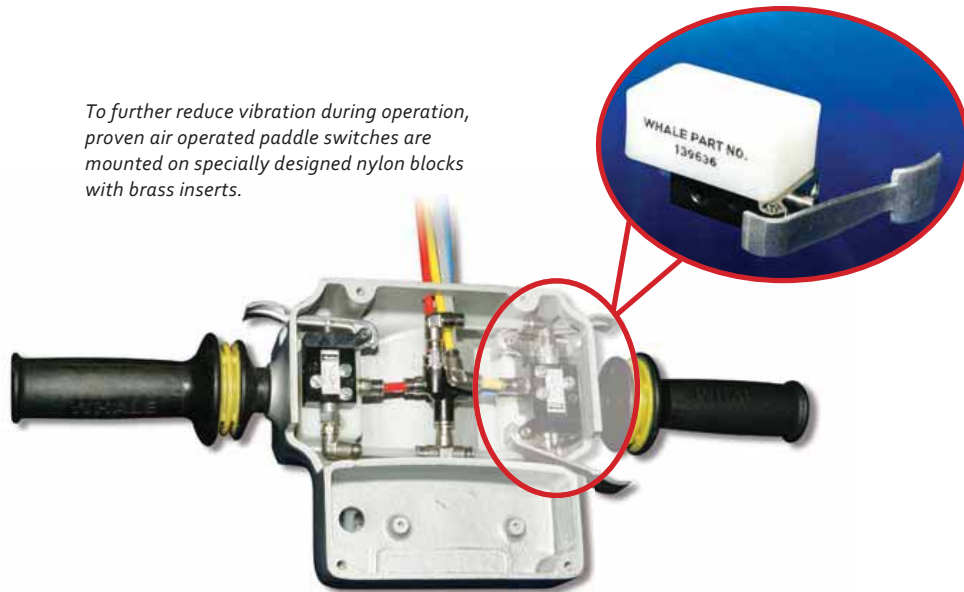

Anyone wishing to order the new gully boom control unit should contact :

**Whale's Parts Department on: 0121 704 5720,
or email: parts@whale.co.uk.**

Alternatively, the unit can also be retrofitted by Whale's experienced team of service engineers.

For further information contact :

**Whale's Service Department on: 0121 704 5710
or email: service@whale.co.uk.**



Whale Tankers Ltd.

Ravenshaw, Solihull, West Midlands,
B91 2SU United Kingdom.

+44(0)121 704 5700

whalemail@whale.co.uk

www.whale.co.uk